

F-431 Transport Package

Parts List

1. Overpack - Body
2. Overpack - Lid (16 Bolts, 5/8-UNC, Gr. 5, 1 Security Seal)
3. Overpack - Inner Lid (16 Bolts, 5/8-UNC, Gr. 5)
4. Gammacell Irradiator (GC1000 or GC3000)
5. Lower Internal Brace
6. Upper Internal Brace
7. Tie-Down Collar (2 pieces)
8. Lifting Hoist Rings (4 pieces)
9. Radiation warning and identification plates (2 sides)
10. Cesium-137 Sources
11. Lead Shielding
12. Shipping Skid

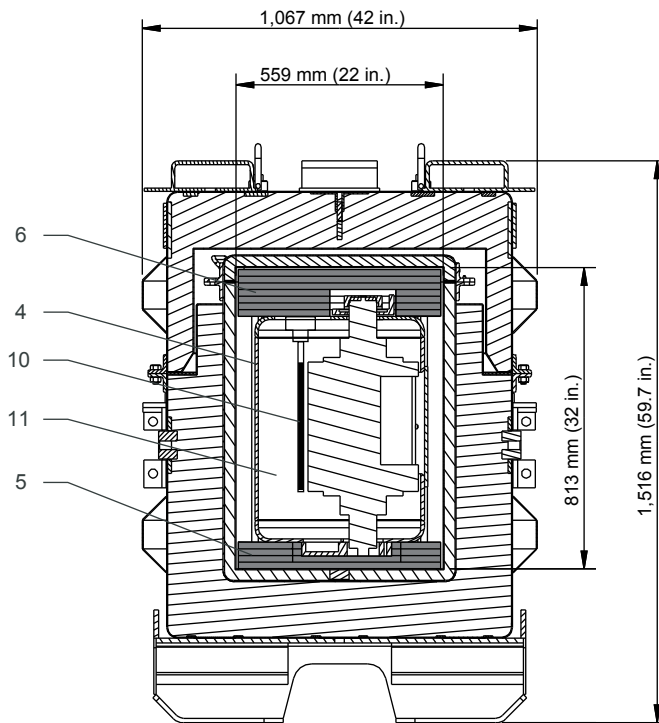
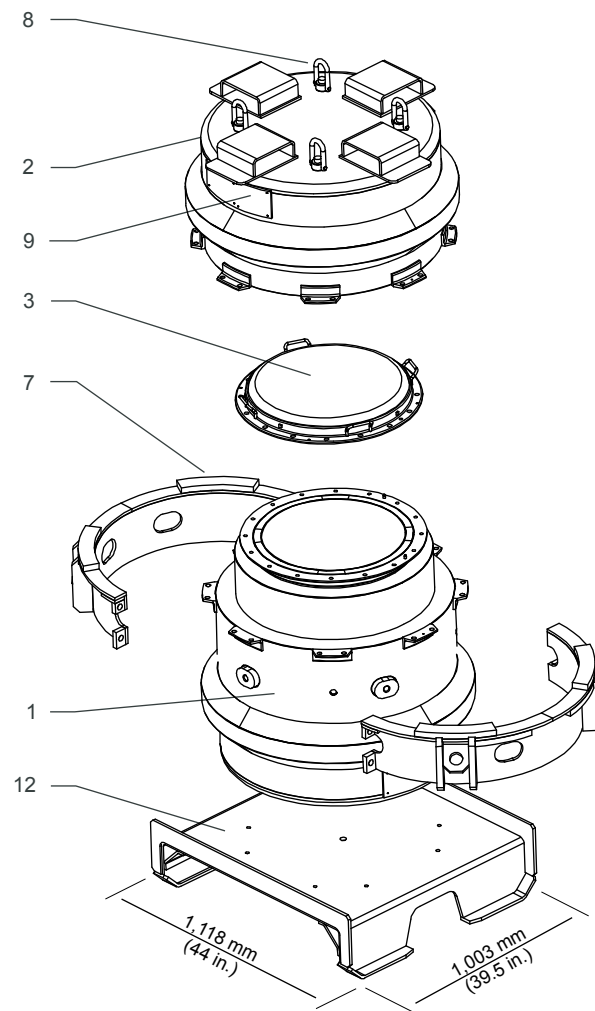

SIDE CROSS-SECTIONAL VIEW

Notes

1. Meets IAEA Type B(U)-96 requirements (CNSC Package Design Certificate No. CDN/2083/B(U)-96)
2. Gross weight: 2,270 kg (5,000 lb.)
3. Floor Loading (based on projected floor area) 2,025 kg/m (415 lb./ft.)
4. Maximum Radioactive contents: 113 TBq (3,050 Ci) of Cs-137
5. Maximum Contents weight: 1,225 kg (2,700 lb.)

Healthcare For Everyone

Team Best® is your single source oncology solutions provider.

“Our Team Best® companies are committed to making quality healthcare affordable and accessible globally.”

Krishnan Suthanthiran
President, Best Medical International

Best Theratronics

413 March Road Ottawa, ON K2K OE4 Canada
Tel: 613 591 2100 1 866 792 8598
Fax: 613 591 6627 www.theratronics.ca

Best medical international

7643 Fullerton Road Springfield, VA 22153 USA
Tel: 703 451 2378 1 800 336 4970
Fax: 703 451 5228 www.teambest.com

BT/MTS 8005 GC1000E (1)

CE0086

Best
Theratronics



Best
healthcare for everyone

© 2008 All Rights Reserved. Best Theratronics, Gammacell 1000 Elite, Gammacell 3000 Elan are registered trademarks of Best Theratronics Ltd. © 2008 Best Theratronics. The specifications contained in this brochure are subject to change.

AFRICA | ASIA | EUROPE | LATIN AMERICA | MIDDLE EAST | NORTH AMERICA

Gammacell® 1000 Elite / 3000 Elan
Superior Performance and Unparalleled Dose Uniformity

Superior Performance and Unparalleled Dose Uniformity

Best® Theratronics products and services are used throughout the world to prevent, diagnose and treat disease. Our applied research and innovation play an integral part in improving global healthcare.

Gammacell® 1000 Elite / 3000 Elan

Graft-Versus-Host Disease

Transfusion-Associated GVHD (TA-GVHD) has become a major concern in current transfusion practices for immuno-deficient and immunosuppressed patients because of the associated high mortality rate. Immunosuppressive therapies have not proven effective for TA-GVHD.

Preventing TA-GVHD

Because patient treatment of TA-GVHD is almost always ineffective, management must focus on prevention by minimizing the risk of developing the condition. Prevention has centered on reducing or inactivating transfused donor lymphocytes. The methods presently available in blood banks to physically remove T lymphocytes through washing or filtration do not provide effective prophylaxis against TA-GVHD. Inactivation of transfused lymphocytes with the use of gamma irradiation of blood components remains the most efficient method for inhibiting lymphocyte blast transformation and mitotic activity and hence preventing TA-GVHD.

Adapted from Transfusion Medicine Topic Update, August 1996, Yale University School of Medicine, University of Connecticut School of Medicine

Features

Safe to Use

- For use in any conventional hospital, clinic or laboratory environment.

Quality Assurance

- An advanced monitoring and control system tracks the irradiation process, confirming canister rotation, irradiation time and product position.

Easy to Operate

- Multi-line, menu driven, display screen with step-by-step instructions, will continue to operate for multiple cycles even in a power outage.

Built-in Security

- Restricts access to the programming function with security passwords and key lock.

Barcode Reading Capabilities

- Can scan ISBT-128, Codabar, and other blood labelling. Includes collection center, unit number, product code, blood type, collection and expiry dates.

Digital Traceability

- Various options for electronic record keeping of irradiated product data.

(Optional) Components for Research

- Optional components for research applications including test tube and animal holders.

Advanced Design Features



Virtually all cellular blood components have been implicated in reported cases of TA-GVHD. The syndrome has developed after transfusion of whole blood, red blood cells, platelets, fresh (non-frozen) plasma and leukocytes harvested from both normal donors and donors with chronic myelocytic leukemia. Current medical practice and the AABB recommend using irradiated blood for immuno-incompetent or immuno-compromised patients.

Blood Irradiation Guidelines:

FDA¹ (2000)

- 15 Gy minimum; 25 Gy central; 50 Gy maximum

Council of Europe² (2003)

- 25 Gy minimum; 50 Gy maximum

UK³ (1996)

- 25 Gy minimum; 50 Gy maximum

1 License Amendments and Procedures for Gamma Irradiation of Blood and Blood Components US FDA, Center for Biologics Evaluation & Research, February 2000
2 Guide to the preparation, use and quality assurance of blood components, 9th Edition, Council of Europe Publishing, 2003
3 Guidelines on Gamma Irradiation of Blood Components for the prevention of Transfusion-Association Graft-Versus-Host Disease, BCSH Blood Transfusion Task Force, February 1996

- State-of-the-art control system is based on a software platform making future upgrades easy, and allowing for advanced trouble-shooting capability:
- Able to scan key barcoded parameters from the blood bag (including RadTag™ indicators)
- Capable of generating a complete record of the irradiation cycle when connected to a printer or computer
- Ergonomic design for easy loading and unloading of blood bags
- Caesium¹³⁷ is double-encapsulated in stainless steel
- Ethernet (web browser) access and LIMS interface provide digital traceability options for blood products.
- Multiple control systems for monitoring timing, beaker rotation and position of product
- Four line vacuum fluorescent display with step-by-step user instructions
- Modular design of control system for easy maintenance and upgrades
- Bypass mode
- Battery back-up
- Relocation and disposal services
- Barcode reading capabilities*

* Optional – able to read ISBT 128, codabar and code 39 barcode types

Specifications	GC 1000 Elite	GC 3000 Elan
Weight	1150 kg (2,535 lb.)	1479 kg (3,260 lb.)
Floor Loading	1467 kg/m ² (301 lb./sq. ft.)	1886 kg/m ² (388 lb./sq. ft.)
Radiation Source	Caesium ¹³⁷	Caesium ¹³⁷
Physical Dimensions (height x width x depth)	1550 mm x 788 mm x 1041 mm 61 in. x 31 in. x 41 in.	1550 mm x 788 mm x 1041 mm 61 in. x 31 in. x 41 in.
External Radiation Fields (typical)	less than 20 µSv/h (2 mrem/h) at 5 cm (1.97 in.) from surface	less than 10 µSv/h (1 mrem/h) at 5 cm (1.97 in.) from surface
Initial Normal Activity *	24.1 TBq, 53.7 TBq or 107.4 TBq 575 Ci, 1450 Ci or 2900 Ci	53.7 TBq or 107.4 TBq 1450 Ci or 2900 Ci
Canister Volume	0.824 L	2.34 L
Central Dose Rate ± 20% (in water)	4 Gy/min (575 Ci) 8.5 Gy/min (1450 Ci) 16.0 Gy/min (2900 Ci)	5 Gy/min (1450 Ci) 9.75 Gy/min (2900 Ci)
Time to Deliver 25 Gy (centre) to Blood Products	7.14 min (575 Ci) 2.9 min (1450 Ci) 1.6 min (2900 Ci)	5 min (1450 Ci) 2.56 min (2900 Ci)
Time to Deliver 30 Gy (centre) to Blood Products	8.6 min (575 Ci) 3.5 min (1450 Ci) 1.9 min (2900 Ci)	6 min (1450 Ci) 3.1 min (2900 Ci)
Dose Uniformity (typical) 25 Gy to centre	21 Gy (minimum) 29 Gy (maximum)	19 Gy (minimum) 33 Gy (maximum)
Dose Uniformity (typical) 25 Gy to minimum	30 Gy (central) 35 Gy (maximum)	33 Gy (central) 43.5 Gy (maximum)**

* Other low activity sources available upon request, subject to availability ** Can be reduced to 40 Gy with our special source holder

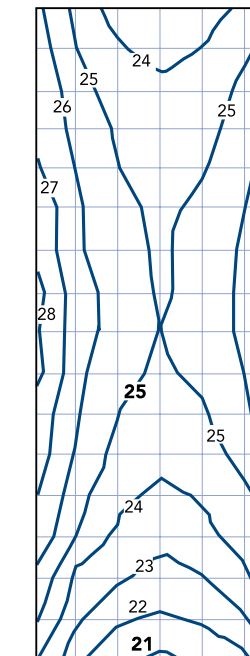

Typical Dose Uniformity

Exceptional dose uniformity is critical to ensuring a tight dose delivery to the product. This diagram illustrates the high dose uniformity delivered by the Gammacell 1000 when 25 Gy is targeted to the centre of the canister.